

800G OSFP 2xDR4 Transceiver

S-OS800G31DM1205-CD

Features

- Hot-pluggable OSFP form factor
- EML transmitter and PIN PD receiver
- Support 850Gb/s aggregate bit rate
- Compliant with IEEE 802.3cu-2021 -8x100GBASE-DR optical interface
- Compliant with IEEE 802.3ck-2022:- 8x100GAUI-1 C2M electrical interface
- Compliant with InfiniBand Trade Association (IBTA) Specification 1.6- InfiniBand NDR electrical and optical interface
- Compliant with OSFP MSA Specification Rev 5.0 Type 2 housing with Dual MPO-12/APC receptacle
- Compliant with CMIS Rev 5.0
- Case operating temperature 0°C to 70°C
- Two wire serial Interface with digital diagnostic monitoring
- Complies with EU Directive 2011/65/EU (RoHS compliant)
- Class 1 Laser

Applications

- Data Center 800GE 500m SMF links
- Support both Ethernet and InfiniBand NDR

Functional Block Diagram

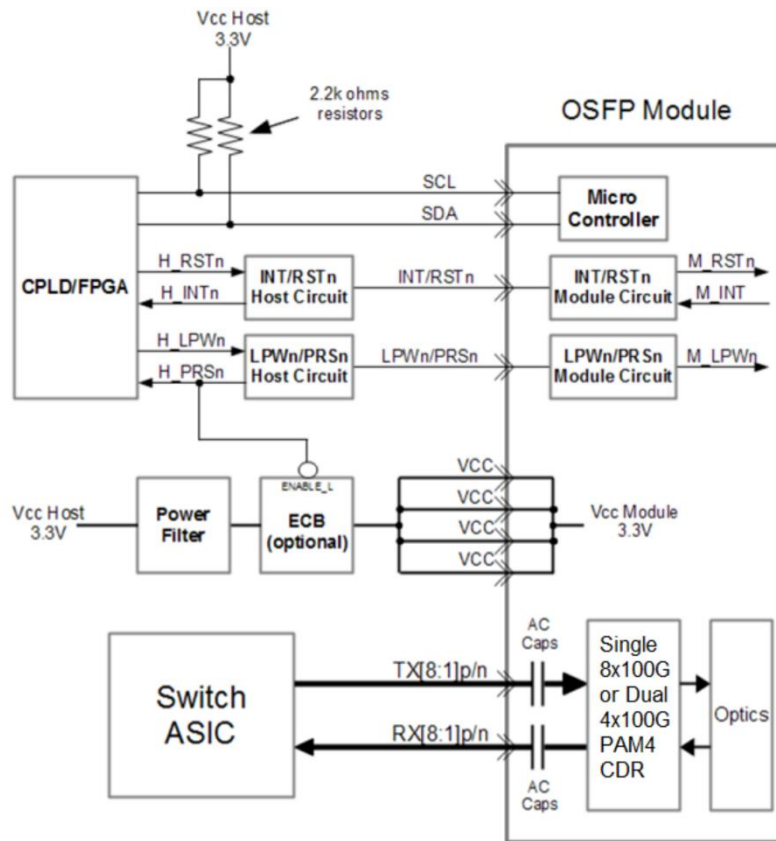

Figure 1 Functional Block Diagram

Absolute Maximum Ratings

Stresses in excess of the absolute maximum ratings can cause permanent damage to the device. These are absolute stress ratings only. Functional operation of the device is not implied at these or any other conditions in excess of those given in the operational sections of the data sheet. Exposure to absolute maximum ratings will cause permanent damage and/or adversely affect device reliability.

Table 1 Absolute Maximum Ratings

No.	Parameter	Symbol	Min.	Max.	Unit	Remarks
1	Storage Temperature	T_s	-40	85	°C	
2	Supply Voltage	V_{CC}	-0.5	3.6	V	+3.3 V
3	Relative Humidity (non-condensing)	RH	5	95	%	
4	Data Input Voltage Differential	$ V_{DIP} - V_{DIN} $	-	1	V	
5	Control Input Voltage	V_I	-0.3	$V_{CC} + 0.5$	V	
6	Control Output Current	I_o	-20	20	mA	

Operating Environments

Electrical and optical characteristics below are defined under this operating environment, unless otherwise specified.

Table 2 Operating Environment

No	Parameter	Symbol	Min.	Typ.	Max.	Unit	Remarks
1	Operating Case Temperature	T _{OPR}	0	-	70	°C	Note 1
2	Power Supply Voltage	V _{CC}	3.135	3.3	3.465	V	
3	Instantaneous peak current at hot plug	I _{CC_IP}	-	-	6600	mA	
4	Sustained peak current at hot plug	I _{CC_SP}	-	-	5494.5	mA	
5	Maximum Power Dissipation	P _D	-	-	16.5	W	
6	Maximum Power Dissipation, Low Power Mode	P _{DLP}	-	-	2	W	
7	Signalling Speed per Lane	DRL	-	53.125	-	GBd	
8	Control Input Voltage High	V _{IH}	V _{CC} *0.7	-	V _{CC} +0.3	V	
9	Control Input Voltage Low	V _{IL}	-0.3	-	V _{CC} *0.3	V	
10	Two Wire Serial Interface Clock Rate	-	-	-	400	kHz	
11	Power Supply Noise 1 kHz - 1 MHz (p-p)	-	-	-	66	mVpp	
12	Operating Distance	-	2	-	500	m	

Note 1: Average launch power, each lane (min) is informative and not the principal indicator of signal strength

Electrical Interface

Table 3 Electrical Characteristics

No.	Parameter	Min.	Typ.	Max.	Unit	Remarks
Module output (each lane, at TP4)						
1	Peak-to-peak AC common-mode voltage Low-frequency, VCMLF Full-band, VCMFB	-	-	32 80	mV	
2	Differential peak-to-peak output voltage Short mode Long mode	-	-	600 845	mV	
3	Eye height	15	-	-	mV	
4	Vertical eye closure	-	-	12	dB	
5	Common-mode to differential-mode return loss	802.3ck 120G-1			dB	
6	Effective return loss	8.5	-	-	dB	
7	Differential termination mismatch	-	-	10	%	
8	Transition time	8.5	-	-	ps	
9	DC common-mode voltage tolerance	-0.35	-	2.85	V	
Module input (each lane, at TP1)						
1	Differential pk-pk input Voltage tolerance (TP1a)	750	-	-	mV	
2	Peak-to-peak AC common-mode voltage tolerance Low-frequency, VCMLF Full-band, VCMFB	-	-	32 80	mV	
3	Differential-mode to common-mode return loss	802.3ck 120G-2			dB	

4	Effective return loss	8.5	-	-	dB	
5	Differential termination mismatch	-	-	10	%	
6	Single-ended voltage tolerance range	-0.4	-	3.3	V	
7	DC common-mode voltage tolerance	-0.35	-	2.85	V	

Optical Interface

Table 4 Transmitter Characteristics

No.	Parameter	Symbol	Min.	Typ.	Max.	Unit	Remarks
1	Wavelength	λ_c	1304.5	1311	1317.5	nm	
2	Side Mode Suppression Ratio	SMSR	30	-	-	dB	
3	Average Launch Power, each lane	AOP _L	-2.9	-	4.0	dBm	Note 1
4	Outer Optical Modulation Amplitude (OMA _{outer}), each Lane	T _{OMA}	-0.8	-	4.2	dBm	
5	Launch power in OMA _{outer} minus TDECQ, each lane for extinction ratio ≥ 5 dB for extinction ratio < 5 dB	T _{OMA-TDECQ}	-2.2 -1.9	-	-	dBm	
6	Transmitter and Dispersion Eye Closure for PAM4 (TDECQ), each lane	TDECQ	-	-	3.4	dB	
7	TDECQ – 10log10(Ceq), each lane	Ceq	-	-	3.4	dB	
8	Average Launch Power of OFF Transmitter, each lane	T _{OFF}	-	-	-15	dBm	
9	Extinction Ratio	ER	3.5	-	-	dB	
10	Transmitter transition time	T _r			17	ps	
11	RIN _{15.5OMA}	RIN	-	-	-136	dB/Hz	
12	Optical return loss tolerance	ORL	-	-	15.5	dB	
13	Transmitter Reflectance	T _R	-	-	-26	dB	Note 2

Note 1: Average launch power, each lane (min) is informative and not the principal indicator of signal strength

Note 2: Transmitter reflectance is defined looking into the transmitter.

Table 5 Receiver Characteristics

No.	Parameter	Symbol	Min.	Typ.	Max.	Unit	Remarks
1	Wavelength	λ_{co}	1304.5	1311	1317.5	nm	
2	Damage Threshold, each Lane	AOP _D	5	-	-	dBm	
3	Average Receive Power, each Lane	AOP _R	-5.9	-	4	dBm	
4	Receive Power (OMA _{outer}), each Lane	OMA _R	-	-	4.2	dBm	
5	Receiver Reflectance	RR	-	-	-26	dB	
6	Receiver Sensitivity (OMA _{outer}), each Lane	S _{OMA}	-	-	Max(-3.9, SECC - 5.3)	dBm	Note 1

No.	Parameter	Symbol	Min.	Typ.	Max.	Unit	Remarks
7	Stressed Receiver Sensitivity (OMAouter), each Lane	SRS	-	-	-1.9	dBm	Note 2
	Conditions of stressed receiver sensitivity test						
8	Stressed eye closure for PAM4 (SECQ), lane under test	SECQ	-	3.4	-	dB	
9	SECQ – 10log10(Ceq), lane under test	Ceq	-	-	3.4	dB	

Note 1:Receiver sensitivity (OMAouter), each lane (max) is informative and is defined for a transmitter with a value of SECQ up to 3.4 dB.

Note 2: Measured with conformance test signal at TP3 for the BER = 2.4x10-4

CONTROL INTERFACE

Table 6 Low Speed Control and Sense Signals































Parameter	Symbol	Min	Max	Unit	Condition
Module output SCL and SDA	V _{OL}	0	0.4	V	
Module Input SCL and SDA	V _{IL}	-0.3	V _{CC} *0.3	V	
	V _{IH}	V _{CC} *0.7	V _{CC} +0.5	V	
INT/RSTn	Comply with OSFP MSA 5.0 Table 13-4				

Table 7 Digital Diagnostics

Parameter	Range	Accuracy	Unit	Calibration
Temperature	0 to 70	±3	°C	Internal
Voltage	3.135 to 3.465	±3%	V	Internal
Tx Bias Current (Each Lane)	0 to 100	10%	mA	Internal
Tx Output Power (Each Lane)	-2.9 to +4	±3	dB	Internal
Rx Receive Power (Each Lane)	-5.9 to +4	±3	dB	Internal

PIN ASSIGNMENT

Top Side (viewed from top)

60	GND	
59	TX1p	
58	TX1n	
57	GND	
56	TX3p	
55	TX3n	
54	GND	
53	TX5p	
52	TX5n	
51	GND	
50	TX7p	
49	TX7n	
48	GND	
47	SDA	
46	VCC	
45	VCC	
44	INT/RSTn	
43	GND	
42	RX8n	
41	RX8p	
40	GND	
39	RX6n	
38	RX6p	
37	GND	
36	RX4n	
35	RX4p	
34	GND	
33	RX2n	
32	RX2p	
31	GND	

-----Module Card Edge -----

Bottom Side (viewed from bottom)































	GND	1
	TX2p	2
	TX2n	3
	GND	4
	TX4p	5
	TX4n	6
	GND	7
	TX6p	8
	TX6n	9
	GND	10
	TX8p	11
	TX8n	12
	GND	13
	SCL	14
	VCC	15
	VCC	16
	LPWn/PRSn	17
	GND	18
	RX7n	19
	RX7p	20
	GND	21
	RX5n	22
	RX5p	23
	GND	24
	RX3n	25
	RX3p	26
	GND	27
	RX1n	28
	RX1p	29
	GND	30

Table 8 Module Pin Definitions

Pin #	Symbol	Description	Logic	Pin #	Symbol	Description	Logic
1	GND	Ground		31	GND	Ground	
2	TX2p	Transmitter Data Non-Inverted	CML-I	32	RX2p	Receiver Data Non-Inverted	CML-O
3	TX2n	Transmitter Data Inverted	CML-I	33	RX2n	Receiver Data Inverted	CML-O
4	GND	Ground		34	GND	Ground	
5	TX4p	Transmitter Data Non-Inverted	CML-I	35	RX4p	Receiver Data Non-Inverted	CML-O
6	TX4n	Transmitter Data Inverted	CML-I	36	RX4n	Receiver Data Inverted	CML-O
7	GND	Ground		37	GND	Ground	
8	TX6p	Transmitter Data Non-Inverted	CML-I	38	RX6p	Receiver Data Non-Inverted	CML-O
9	TX6n	Transmitter Data Inverted	CML-I	39	RX6n	Receiver Data Inverted	CML-O
10	GND	Ground		40	GND	Ground	
11	TX8p	Transmitter Data Non-Inverted	CML-I	41	RX8p	Receiver Data Non-Inverted	CML-O
12	TX8n	Transmitter Data Inverted	CML-I	42	RX8n	Receiver Data Inverted	CML-O
13	GND	Ground		43	GND	Ground	
14	SCL	2-wire Serial interface clock	LVCM OS- I/O	44	INT/RST n	Module Interrupt / Module Reset	Multi-Level
15	VCC	+3.3V Power		45	VCC	+3.3V Power	
16	VCC	+3.3V Power		46	VCC	+3.3V Power	
17	LPWn/ P RSn	Low-Power Mode / Module Present	Multi-Level	47	SDA	2-wire Serial interface data	LVCM OS-I/O
18	GND	Ground		48	GND	Ground	
19	RX7n	Receiver Data Inverted	CML-O	49	TX7n	Transmitter Data Inverted	CML-I
20	RX7p	Receiver Data Non-Inverted	CML-O	50	TX7p	Transmitter Data Non-Inverted	CML-I
21	GND	Ground		51	GND	Ground	
22	RX5n	Receiver Data Inverted	CML-O	52	TX5n	Transmitter Data Inverted	CML-I
23	RX5p	Receiver Data Non-Inverted	CML-O	53	TX5p	Transmitter Data Non-Inverted	CML-I
24	GND	Ground		54	GND	Ground	
25	RX3n	Receiver Data Inverted	CML-O	55	TX3n	Transmitter Data Inverted	CML-I
26	RX3p	Receiver Data Non-Inverted	CML-O	56	TX3p	Transmitter Data Non-Inverted	CML-I
27	GND	Ground		57	GND	Ground	
28	RX1n	Receiver Data Inverted	CML-O	58	TX1n	Transmitter Data Inverted	CML-I
29	RX1p	Receiver Data Non-Inverted	CML-O	59	TX1p	Transmitter Data Non-Inverted	CML-I
30	GND	Ground		60	GND	Ground	

MECHANICAL DIMENSIONS

Unit: mm

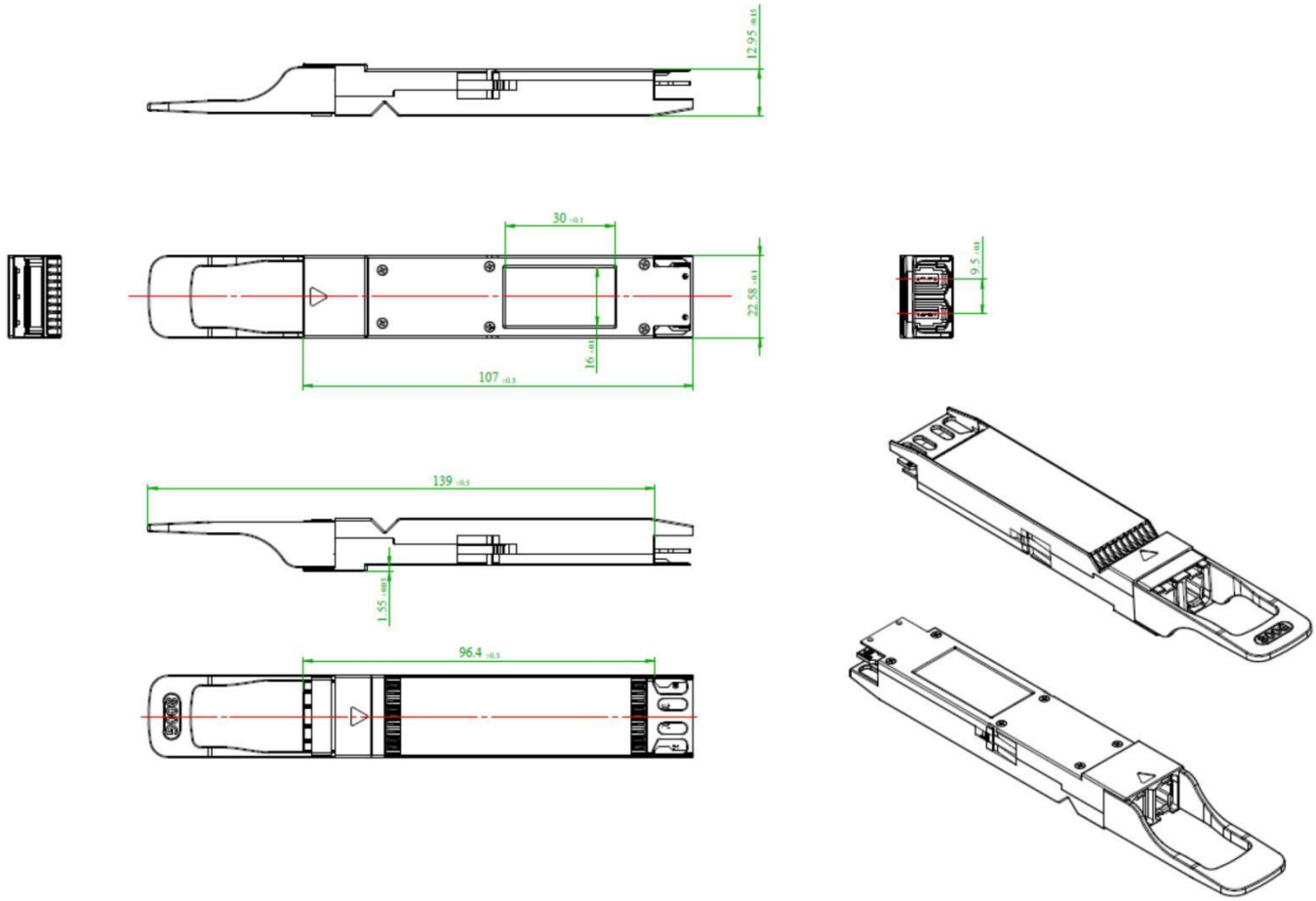

Ordering Information

Part Number	Description
S-OS800G31DM1205-CD	ZKTeI-800Gb/s OSFP 500m MPO 0°C~+70°C with DDM