

25G T1330/R1270nm 10km BIDI SFP28 Optical Transceiver Module

S-PB2532L10-CD

Features

- Supports up to 25.78Gbps bit rates
- Hot-pluggable SFP+ footprint
- 1330nm DFB laser and PIN photodiode, Up to 10km for SMF transmission
- Compliant with SFP+ MSA and SFF-8472 with duplex LC receptacle
- Single +3.3V power supply
- Real Time Digital Diagnostic Monitoring
- Operating case temperature: 0 to +70°C
- Compatible with RoHS

Applications

- 25GBASE-LR

Description

SFP28 BIDI transceivers are high performance, cost effective modules supporting data rate of 25.78Gbps and 10km transmission distance with SMF.

The transceiver consists of three sections: a DFB laser transmitter, a PIN photodiode integrated with a trans-impedance preamplifier (TIA) and MCU control unit.

The transceivers are compatible with SFP Multi-Source Agreement and SFF-8472 digital diagnostics functions.

Absolute Maximum Ratings

| Parameter | Symbol | Min | Typ | Max | Unit |
|-------------------------------|-----------------|------|-----|-----|------|
| Power Supply Voltage | V _{cc} | -0.5 | | 4.5 | V |
| Storage Temperature Range | T _s | -40 | | +85 | °C |
| Relative Humidity - Operating | RH _o | 5 | | 85 | % |

Recommended Operating Conditions

| Parameter | Symbol | Min | Typ | Max | Unit |
|----------------------------------|-----------------|------|-------|------|------|
| Case Operating Temperature Range | T _c | 0 | | +70 | °C |
| Power Supply Voltage | V _{cc} | 3.14 | 3.3 | 3.47 | V |
| Supply Current | I _{cc} | | | 600 | mA |
| Data Rate | BR | - | 25.78 | - | Gbps |

25G T1330/R1270nm 10km BIDI SFP28 Optical Transceiver Module

S-PB2532L10-CD

Optical and Electrical Characteristics

| Parameter | | Symbol | Min | Typical | Max | Unit | Notes |
|--------------------------------|---------|-----------------|------|---------|------|----------|-------|
| Transmitter | | | | | | | |
| Centre Wavelength | | λ_c | 1320 | 1330 | 1340 | nm | |
| Spectral Width (-20dB) | | $\Delta\lambda$ | | | 1 | nm | |
| Side-Mode Suppression Ratio | | SMSR | 30 | - | | dB | |
| Average Output Power | | P_{out} | -2 | | 4 | dBm | 1 |
| Extinction Ratio | | ER | 3.5 | | | dB | |
| Data Input Swing Differential | | V_{IN} | 180 | | 850 | mV | 2 |
| Input Differential Impedance | | Z_{IN} | 90 | 100 | 110 | Ω | |
| TX Disable | Disable | | 2.0 | | Vcc | V | |
| | Enable | | 0 | | 0.8 | V | |
| TX Fault | Fault | | 2.0 | | Vcc | V | |
| | Normal | | 0 | | 0.8 | V | |
| Receiver | | | | | | | |
| Centre Wavelength | | λ_c | 1260 | 1270 | 1280 | nm | |
| Receiver Sensitivity | | | | | -13 | dBm | 3 |
| Receiver Overload | | | | | 2 | dBm | 3 |
| LOS De-Assert | | LOS_D | | | -15 | dBm | |
| LOS Assert | | LOS_A | -30 | | | dBm | |
| LOS Hysteresis | | | 0.5 | | | dB | |
| Data Output Swing Differential | | V_{out} | 300 | | 900 | mV | 4 |
| LOS | High | | 2.0 | | Vcc | V | |
| | Low | | | | 0.8 | V | |

Notes:

1. The optical power is launched into SMF.
2. PECL input, internally AC-coupled and terminated.
3. Measured with a PRBS $2^{31}-1$ test pattern @25.78Gps, BER $\leq 5 \times 10^{-5}$.
4. Internally AC-coupled.

25G T1330/R1270nm 10km BIDI SFP28 Optical Transceiver Module

S-PB2532L10-CD

Timing and Electrical

| Parameter | Symbol | Min | Typical | Max | Unit |
|---|----------------|-----|---------|-----------------|------|
| Tx Disable Negate Time | t_on | | | 2 | ms |
| Tx Disable Assert Time | t_off | | | 10 | μs |
| Time To Initialize, including Reset of Tx Fault | t_init | | | 300 | ms |
| Tx Fault Assert Time | t_fault | | | 100 | μs |
| Tx Disable To Reset | t_reset | 10 | | | μs |
| LOS Assert Time | t_loss_on | | | 100 | μs |
| LOS De-assert Time | t_loss_off | | | 100 | μs |
| Serial ID Clock Rate | f_serial_clock | | 100 | 400 | KHz |
| MOD_DEF (0:2)-High | V _H | 2 | | V _{cc} | V |
| MOD_DEF (0:2)-Low | V _L | | | 0.8 | V |

Diagnostics

| Parameter | Range | Unit | Accuracy | Calibration |
|--------------|------------|------|----------|-------------|
| Temperature | 0 to +70 | °C | ±3°C | Internal |
| Voltage | 3.0 to 3.6 | V | ±3% | Internal |
| Bias Current | 0 to 100 | mA | ±10% | Internal |
| TX Power | 0 to 6 | dBm | ±3dB | Internal |
| RX Power | -14 to +2 | dBm | ±3dB | Internal |

Digital Diagnostic Memory Map

The transceivers provide serial ID memory contents and diagnostic information about the present operating conditions by the 2-wire serial interface (SCL, SDA).

The diagnostic information with internal calibration or external calibration all are implemented, including received power monitoring, transmitted power monitoring, bias current monitoring, supply voltage monitoring and temperature monitoring.

The digital diagnostic memory map specific data field defines as following.

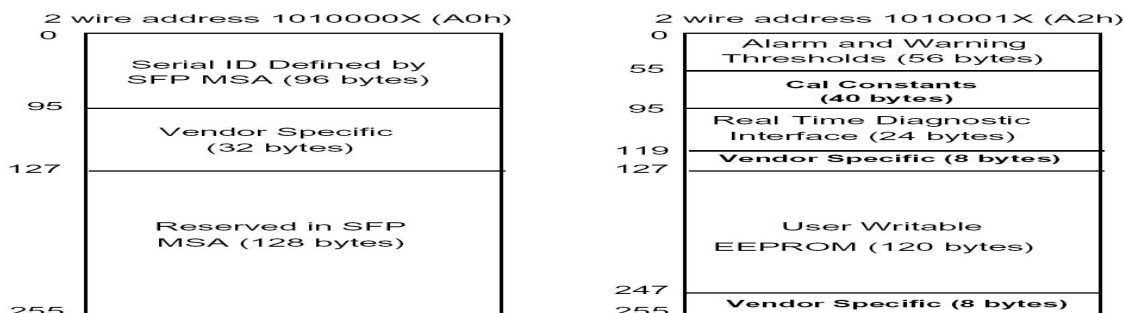

25G T1330/R1270nm 10km BIDI SFP28 Optical Transceiver Module

S-PB2532L10-CD

Pin Definitions

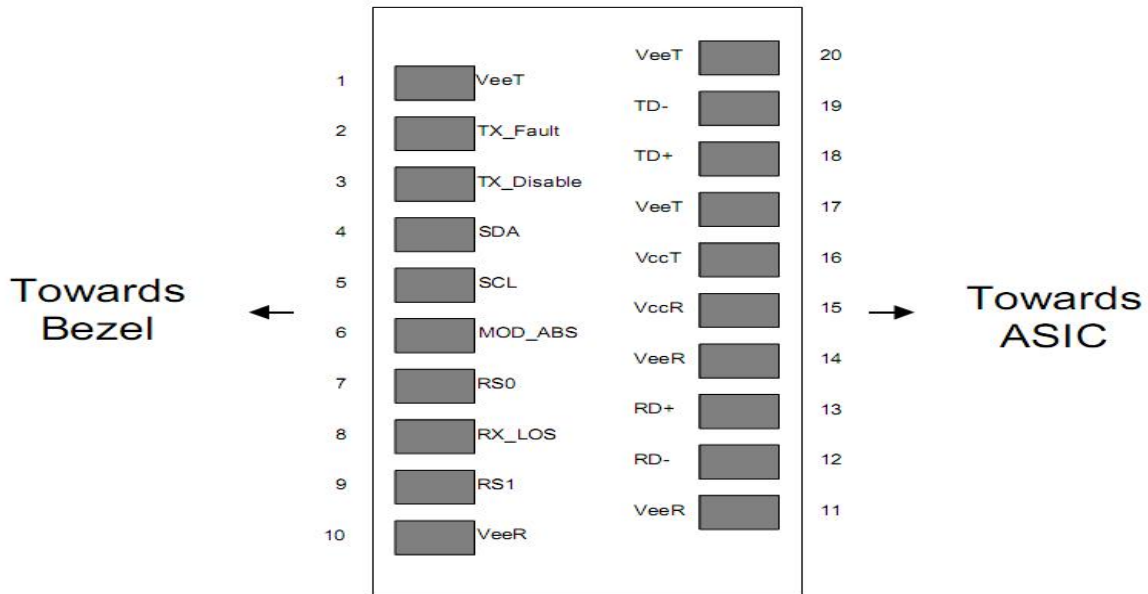

| Pin | Signal Name | Description | Plug Seq. | Notes |
|-----|------------------|---|-----------|--------|
| 1 | V _{EET} | Transmitter Ground | 1 | |
| 2 | TX_FAULT | Transmitter Fault Indication | 3 | Note 1 |
| 3 | TX_DISABLE | Transmitter Disable | 3 | Note 2 |
| 4 | SDA | SDA Serial Data Signal | 3 | |
| 5 | SCL | SCL Serial Clock Signal | 3 | |
| 6 | MOD_ABS | Module Absent. Grounded within the module | 3 | |
| 7 | RS0 | Not Connected | 3 | |
| 8 | LOS | Loss of Signal | 3 | Note 3 |
| 9 | RS1 | Not Connected | 3 | |
| 10 | V _{EER} | Receiver ground | 1 | |
| 11 | V _{EER} | Receiver ground | 1 | |
| 12 | RD- | Inv. Received Data Out | 3 | Note 4 |
| 13 | RD+ | Received Data Out | 3 | Note 4 |
| 14 | V _{EER} | Receiver ground | 1 | |
| 15 | V _{CCR} | Receiver Power Supply | 2 | |
| 16 | V _{CCT} | Transmitter Power Supply | 2 | |

25G T1330/R1270nm 10km BIDI SFP28 Optical Transceiver Module

S-PB2532L10-CD

| | | | | |
|----|------------------|-----------------------|---|--------|
| 17 | V _{EET} | Transmitter Ground | 1 | |
| 18 | TD+ | Transmit Data In | 3 | Note 5 |
| 19 | TD- | Inv. Transmit Data In | 3 | Note 5 |
| 20 | V _{EET} | Transmitter Ground | 1 | |

Notes:

1. TX Fault is an open collector output, which should be pulled up with a 4.7k~10kΩ resistor on the host board to a voltage between 2.0V and V_{cc}+0.3V. Logic 0 indicates normal operation; Logic 1 indicates a laser fault of some kind. In the low state, the output will be pulled to less than 0.8V.
2. Laser output disabled on TDIS >2.0V or open, enabled on TDIS <0.8V.
3. LOS is open collector output. Should be pulled up with 4.7k~10kΩ on host board to a voltage between 2.0V and 3.6V. Logic 0 indicates normal operation; logic 1 indicates loss of signal.
4. RD-/+ : These are the differential receiver outputs. They are internally AC-coupled 100 differential lines which should be terminated with 100Ω (differential) at the user SERDES.
5. TD-/+ : These are the differential transmitter inputs. They are internally AC-coupled, differential lines with 100Ω differential termination inside the module.

Recommended High-speed Interface Circuit

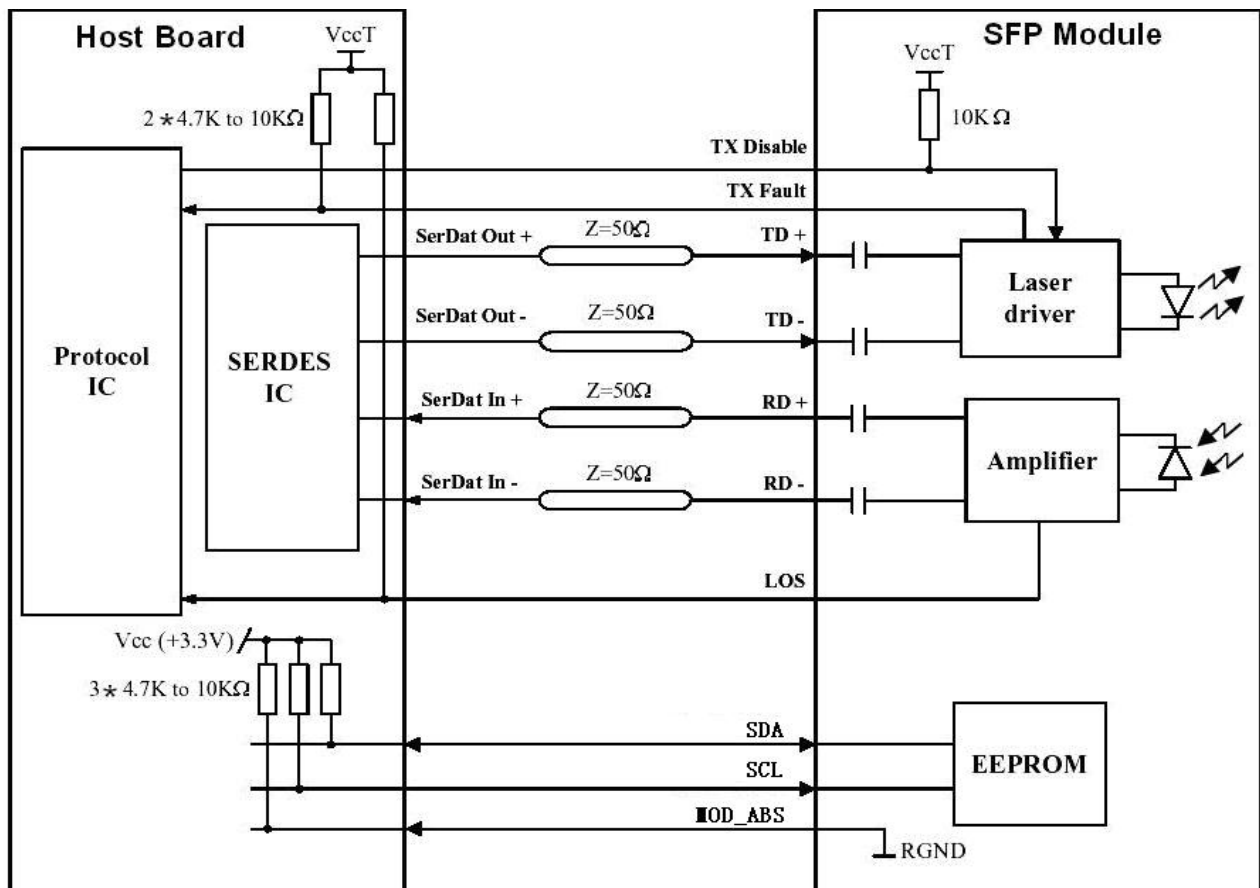

25G T1330/R1270nm 10km BIDI SFP28 Optical Transceiver Module

S-PB2532L10-CD

Mechanical Dimensions

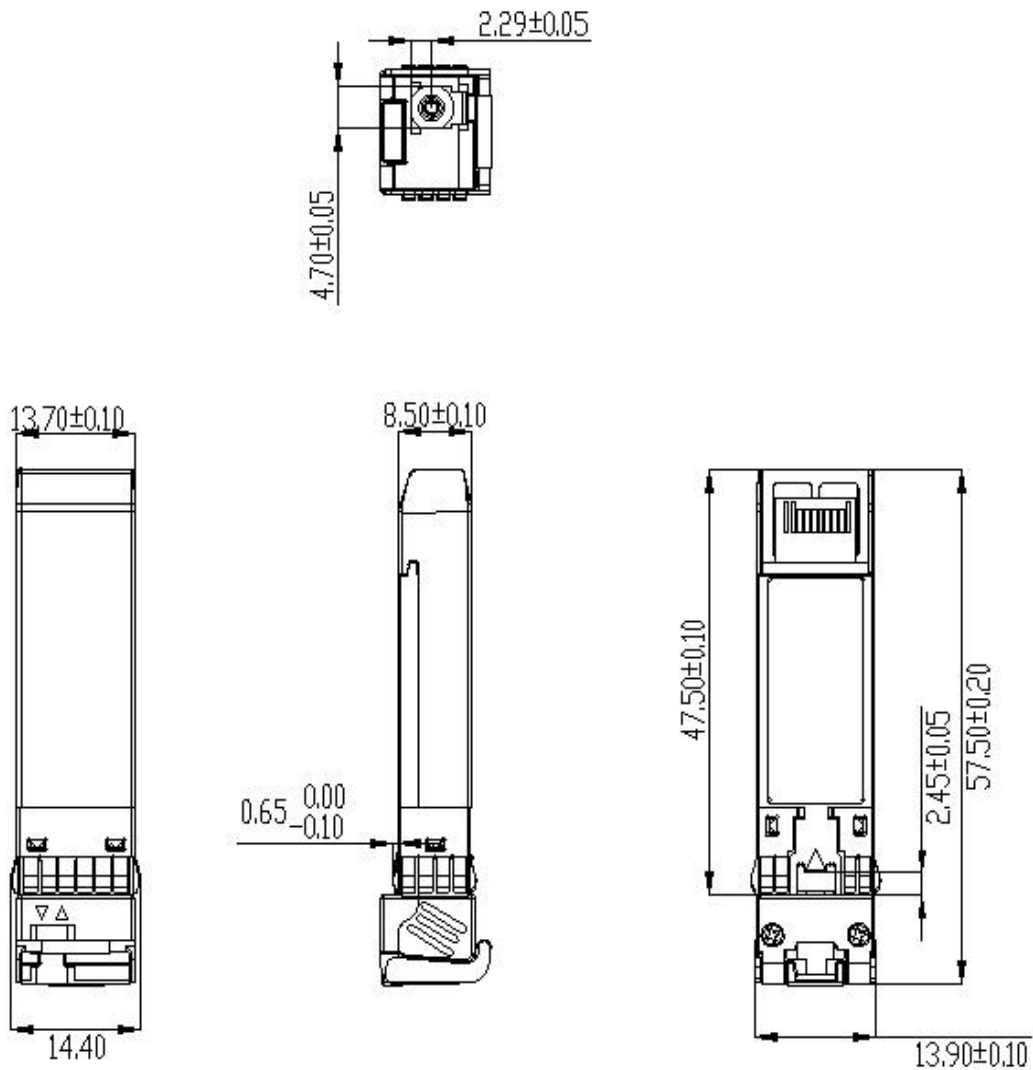

Ordering information

| Part Number | Product Description |
|----------------|---|
| S-PB2532L10-CD | SFP28, BIDI Tx1330/Rx1270nm, 25.78Gbps, SM, 10km, 0°C~+70°C, With DDM |