

25Gbps 850nm 100m SFP28 Optical Transceiver Module

S-PP2585L01-CD

Features

- Hot-pluggable SFP28 form factor
- Supports 25.78125Gbps bit rate
- Maximum link length of 70m on OM3 MMF and 100m on OM4 MMF
- 850nm VCSEL laser and PIN photo detector
- Internal CDR on both Transmitter and Receiver channel
- Duplex LC receptacle
- Single 3.3V power supply
- Low power dissipation: <1.0W
- SFP28 housing with enhanced EMI shielding
- Operating case temperature: 0 to +70°C
- Compatible with RoHS
-

Applications

- Data Center
- 25GBASE-SR Ethernet
- Infiniband EDR Applications
- 32G Fibre Channel Applications
- Servers, Switches, Storage and Host Card Adapters

Standards

- Compliant with SFF-8024、SFF-8431
- Compliant with IEEE802.3by
- Compliant with SFF-8472
- RoHS complaint

Description

SFP28 for 25Gigabit Ethernet and Infiniband EDR Applications. It is a high performance module for short-range data communication and interconnect applications which operate at 25.78125Gbps up to 70m using OM3 fiber or 100m using OM4 fiber. This module is designed to operate over multimode fiber systems using a nominal wavelength of 850nm. The electrical interface uses a 20 contact edge type connector. The optical interface uses duplex LC receptacle.

25Gbps 850nm 100m SFP28 Optical Transceiver Module

S-PP2585L01-CD

Absolute Maximum Ratings

Parameter	Symbol	Min	Typ	Max	Unit
Power Supply Voltage	V _{CC}	-0.5		3.6	V
Storage Temperature Range	T _s	-40		85	°C
Relative Humidity - Operating	RH _o	0		85	%

Recommended Operating Conditions

Parameter	Symbol	Min	Typ	Max	Unit
Case Operating Temperature Range	T _c	0	-	70	°C
Power Supply Voltage	V _{CC}	3.135	3.3	3.465	V
Supply Current	I _{CC}	-	-	300	mA
Data Rate	BR	25.78125±100ppm			Gbps

Electrical Characteristics

Transmitter Electrical Characteristics					
Parameter	Symbol	Min	Typ	Max	Unit
Differential Input Voltage Swing	V _{IN}	90	-	100	mV
Tx Differential Input Impedence	Z _{IN}	-	100	-	Ω
Transmitter Disable Voltage	V _{DIS}	2.0	-	V _{CC} +0.3	V
Transmitter Enable Voltage	V _{EN}	0	-	0.8	V
Receiver Electrical Characteristics					
Parameter	Symbol	Min	Typ	Max	Unit
Differential output Voltage Swing	V _{OUT}	300	-	900	mV
Rx Differential Output Impedence	Z _{OUT}	-	100	-	Ω
LOS Assert Voltage	V _{LOSA}	2.0	-	V _{CC} +0.3	V
LOS De-assert Voltage	V _{LOSD}	-0.3	-	+0.4	V

Optical Characteristics

Parameter	Symbol	Min	Typ	Max	Unit	Notes
Transmitter Characteristics						
Center Wavelength Range	λ	840	850	860	nm	
Spectral Width RMS	Δλ	-	-	0.6	nm	
Average Output Power	P _{avg}	-8.4		2.4	dBm	
Optical Power OMA	P _{OMA}	-6.4		3	dBm	
Extinction Ratio	ER	2	-	-	dB	

25Gbps 850nm 100m SFP28 Optical Transceiver Module

S-PP2585L01-CD

Relative Intensity Noise	RIN	-	-	-128	dB/Hz	
Optical Return Loss Tolerance		-	-	12	dB	
Transmitter and Dispersion Eye Closure	TDEC	-	-	4.3	dB	
Transmitter Eye mask definition {X1,X2, X3, Y1, Y2, Y3}		>10% {0.23, 0.34, 0.43, 0.27, 0.35, 0.4}				1,2
Receiver Characteristics						
Operating Central Wavelength	λ	840	850	860	nm	
Receiver Sensitivity	Sen	-	-	-10.3	dBm	3,4
Receiver Overload	P _{SAT}	2.4	-	-	dBm	
Receiver Reflectance	RFL	-	-	-12	dB	
LOS Assert	LOSA	-30	-	-	dBm	
LOS De-Assert	LOSD	-	-	-13	dBm	
LOS Hysteresis	LOSH	0.5	3	5	dB	
Notes						
1. Transmitter hit ratio 5E-5 hits/sample.						
2. Compliant with IEEE 802.3ba.						
3. Minimum value is informative, equals min Tx OMA with infinite ER and max channel insertion loss.						
4. Receiver Sensitivity measured with a PRBS 2 ³¹ -1 test pattern, @25.78125Gb/s, BER<5E-5.						

Pin Definitions

The SFP+ modules are hot-pluggable. Hot pluggable refers to plugging in or unplugging a module while the host board is powered. The SFP+ host connector is a 0.8 mm pitch 20 position right angle improved connector specified by SFF-8431, or stacked connector with equivalent electrical performance. SFP+ module contacts mates with the host in the order of ground, power, followed by signal as illustrated

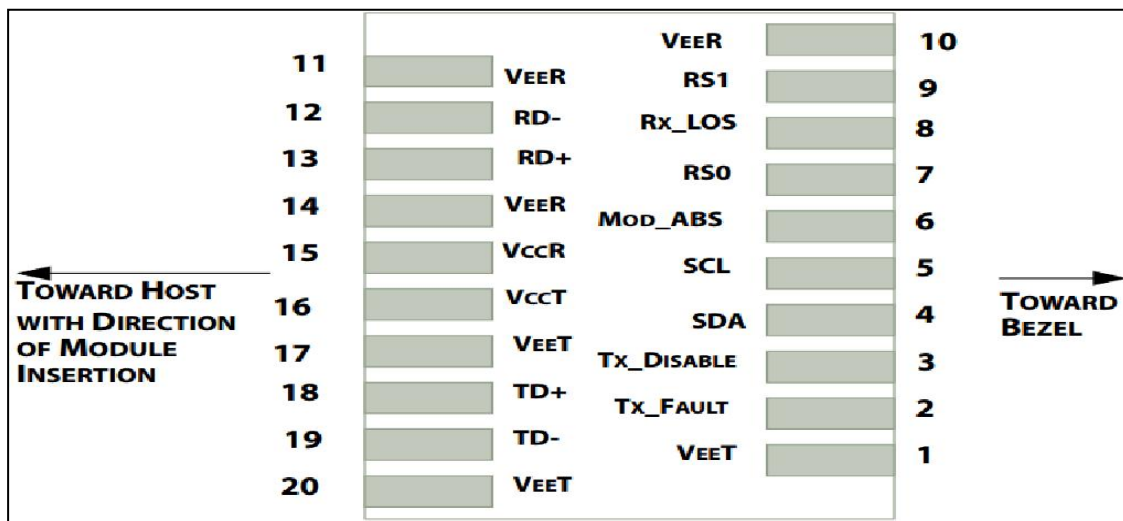

SFP+ Pad Assignment Top View

25Gbps 850nm 100m SFP28 Optical Transceiver Module

S-PP2585L01-CD

Pin	Symbol	Description	Power Seq.	Ref.
1	VeeT	Transmitter Ground	1st	1
2	TX_Fault	Transmitter Fault	3rd	2
3	TX_Disable	Transmitter Disable	3rd	3
4	SDA	2-Wire Serial Interface Data Line	3rd	4
5	SCL	2-Wire Serial Interface Data Line	3rd	4
6	Mod_ABS	Module Absent, Connect to VeeT or VeeR in Module	3rd	5
7	RS0	No connection required	3rd	6
8	RX_LOS	Receiver Loss of Signal indication	3rd	7
9	RS1	No connection required	3rd	8
10	VeeR	Receiver Ground	1st	1
11	VeeR	Receiver Ground	1st	1
12	RD-	Receiver Inverted DATA out. AC Coupled. CML-O	3rd	9
13	RD+	Receiver Non-inverted DATA out. AC Coupled. CML-O	3rd	9
14	VeeR	Receiver Ground	1st	1
15	VccR	Receiver Power Supply	2nd	10
16	VccT	Transmitter Power Supply	2nd	10
17	VeeT	Transmitter Ground	1st	1
18	TD+	Transmitter Non-Inverted DATA in. AC Coupled. CML-I	3rd	11
19	TD-	Transmitter Inverted DATA in. AC Coupled. CML-I	3rd	11
20	VeeT	Transmitter Ground	1st	1

Notes

1. The module signal ground contacts.
2. This pin is an open drain/collector and should be pulled up to Vcc-host in the host with a 4.7k~10k Ohm resistor.
3. This pin should be pulled up to Vcct with a 4.7k~10k Ohm resistor in modules.
4. SDA&SCL (IIC) are needed pull up 4.7k~10k Ohm resistors on host board.
5. Mod_ABS is connected to VeeT or VeeR in the SFP+ module.
6. Rate Select 0,no connection required.
7. Module RX_Los of signal indication need pull up 4.7k~10k Ohm resistor on host board.
8. Rate Select 1,no connection required.
9. RD -/+: These are the differential receiver outputs. They are CML AC-coupled with 100 Ohm terminal resistor matching internal.
10. VccR and VccT are the receiver and transmitter power supplies.
11. TD -/+: These are the differential transmitter inputs. They are CML AC-coupled with 100 Ohm terminal resistor matching internal.

25Gbps 850nm 100m SFP28 Optical Transceiver Module

S-PP2585L01-CD

Optical Module Block Diagram

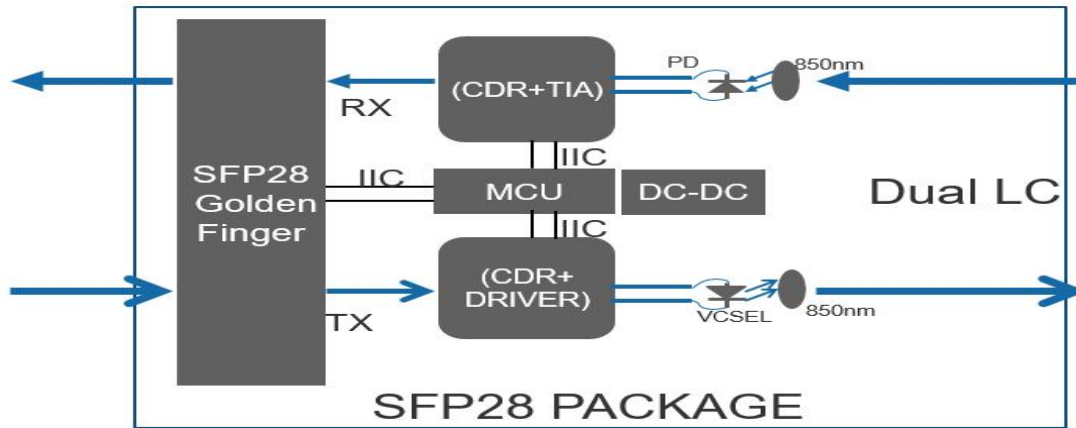

Mechanical Dimensions

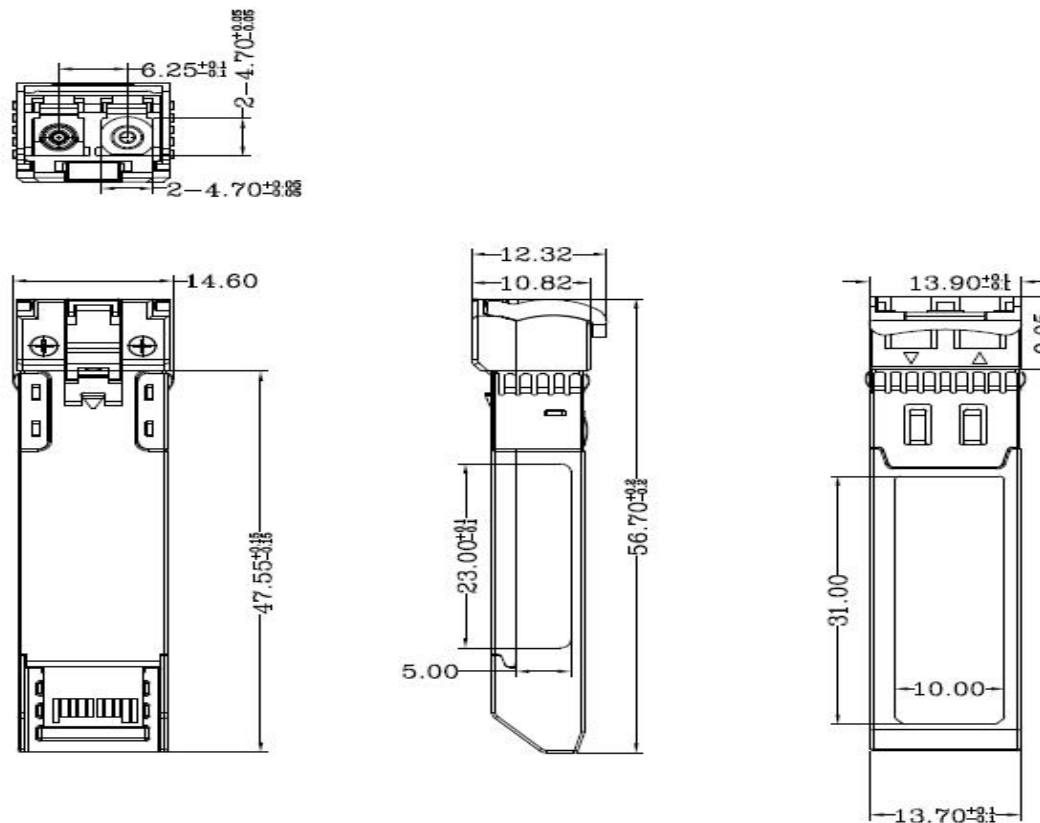

Ordering information

Part Number	Product Description
S-PP2585L03-CD	SFP28, 25.78125Gbps, 850nm, SM, 100m, 0°C~+70°C, With DDM