

1.25G T1310/R1550nm 40km BIDI SFP Optical Transceiver Module

S-SB1G35L40-xD

Features

- Up to 1.25Gbps operation
- +3.3V single power supply
- High-performance and cost-effective
- 1310nm LD and PIN photodetector for 40km transmission
- Compliant with SFP MSA and SFF-8472 with simplex LC receptacle
- Digital Diagnostic Monitoring
- Compatible with SONET OC-24
- Operating case temperature:
 - Commercial: 0 to +70°C
 - Industrial: -40 to +85°C
- RoHS compliant (lead free)

Applications

- Gigabit Ethernet
- Gigabit Fiber Channel
- Switch to Switch interface
- Switched backplane applications
- Router/Server interface
- Other optical transmission systems

Description

BIDI SFP transceivers are high performance, cost effective module supporting 1.25Gbps and 40km transmission distance with SMF(9/125μm).

The transceiver consists of two sections: a 1310nm LD laser transmitter, a PIN photodiode integrated with a trans-impedance amplifier (TIA). BIDI SFP transceiver satisfies class I laser safety requirements.

The transceiver is compatible with SFP Multi-Source Agreement (MSA) and SFF-8472. For further information, please refer to SFP MSA.

Absolute Maximum Ratings

Parameter	Symbol	Min	Typ	Max	Unit
Power Supply Voltage	V _{CC}	-0.5	-	4	V
Storage Temperature Range	T _s	-40	-	85	°C
Relative Humidity - Storage	RH _s	0	-	95	%
Relative Humidity - Operating	RH _o	0	-	85	%

1.25G T1310/R1550nm 40km BIDI SFP Optical Transceiver Module

S-SB1G35L40-xD

Recommended Operating Conditions

Parameter	Symbol	Min	Typ	Max	Unit
Case Operating Temperature Range	T _C	0	-	70	°C
		-40	-	85	
Power Supply Voltage	V _{CC}	3.14	3.3	3.47	V
Supply Current	I _{CC}	-	-	300	mA
Data Rate	BR	-	1.25	-	Gbps

Electrical Characteristics

Transmitter Electrical Characteristics					
Parameter	Symbol	Min	Typ	Max	Unit
Differential Input Voltage Swing	V _{IN}	400	-	2000	mV
Tx Differential Input Impedence	Z _{IN}	-	100	-	Ω
Transmitter Disable Voltage	V _{DIS}	2.0	-	V _{CC} +0.3	V
Transmitter Enable Voltage	V _{EN}	0	-	0.8	V
T _{FAULT} Logic High	V _{TFH}	2.4	-	V _{CC}	V
T _{FAULT} Logic Low	V _{TFL}	V _{EE}	-	V _{EE} +0.4	V
Receiver Electrical Characteristics					
Parameter	Symbol	Min	Typ	Max	Unit
Differential output Voltage Swing	V _{OUT}	400	-	1000	mV
Rx Differential Output Impedence	Z _{OUT}	-	100	-	Ω
LOS Assert Voltage	V _{LOSA}	2.4	-	V _{CC}	V
LOS De-assert Voltage	V _{LOSD}	V _{EE}	-	V _{EE} +0.4	V

Optical Characteristics

Transmitter Characteristics						
Parameter	Symbol	Min	Typ	Max	Unit	Notes
Laser Type		LD				
Data Rate	-	-	1.25	-	Gb/s	
Center Wavelength Range	λ	1260	1310	1360	nm	
Spectral Width@-20dB	Δλ	-	-	1	nm	
Average Launch power of OFF transmitter	P _{OFF}	-	-	-40	dBm	
Launch Optical Power	P _{out}	-5	-	0	dBm	1
Extinction Ratio	ER	9	-	-	dB	
Eye Diagram	Complies with IEEE802.3z eye masks when filtered					

1.25G T1310/R1550nm 40km BIDI SFP Optical Transceiver Module

S-SB1G35L40-xD

Receiver Characteristics						
Receiver Type			PIN			
Data Rate	-	-	1.25	-	Gb/s	
Operating Central Wavelength	λ	1500	1550	1580	nm	
Receiver Sensitivity	Sen	-	-	-25	dBm	2
Receiver Overload	P _{SAT}	-3	-	-	dBm	
LOS Assert	LOSA	-40	-	-	dBm	
LOS De-Assert	LOSD	-	-	-25	dBm	
LOS Hysteresis	LOSH	0.5	3	5	dB	
Notes						
1. Average power figures are informative only, per IEEE802.3z						
2. Measured with 2 ⁷ -1 PRBS@1.25Gbps, BER<10 ⁻¹²						

Pin Definitions

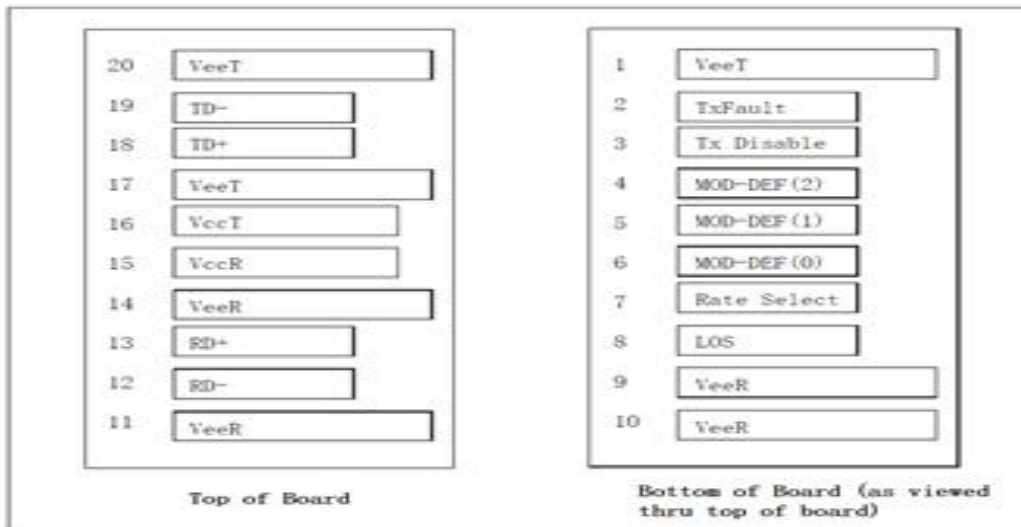

PIN Assignment			
PIN	Symbol	Description	Notes
1	V _{EET}	Transmitter Ground	
2	Tx_FAULT	Transmitter Fault	1
3	Tx_DIS	Transmit Disable	1
4	MOD_DEF 2	Serial Data	1
5	MOD_DEF 1	Clock Signal	1

1.25G T1310/R1550nm 40km BIDI SFP Optical Transceiver Module

S-SB1G35L40-xD

6	MOD_DEF 0	Interface Digital Ground	
7	Rate Select	Not Connected	
8	Rx_LOS	Receiver Loss of Signal	1
9	V _{EER}	Receiver Ground	
10	V _{EER}	Receiver Ground	
11	V _{EER}	Receiver Ground	
12	RD-	Rx_Data Output (Inverted)	
13	RD+	Rx_Data Output (Non Inverted)	
14	V _{EER}	Receiver Ground	
15	V _{CCR}	Receiver DC Power	
16	V _{CCT}	Transmitter DC Power	
17	V _{EET}	Transmitter Ground	
18	TD+	Tx_Data Input (Non Inverted)	
19	TD-	Tx_Data Input (Inverted)	
20	V _{EET}	Transmitter Ground	

Notes

1. The uncommitted Tx_Fault, Rx_LOS, MOD_DEF 1 and MOD_DEF 2 LVTTTL monitor and control pins each require a pull up resistor of 4.7k to 10k Ohms on the host board.

1.25G T1310/R1550nm 40km BIDI SFP Optical Transceiver Module

S-SB1G35L40-xD

Recommended Interface Circuit

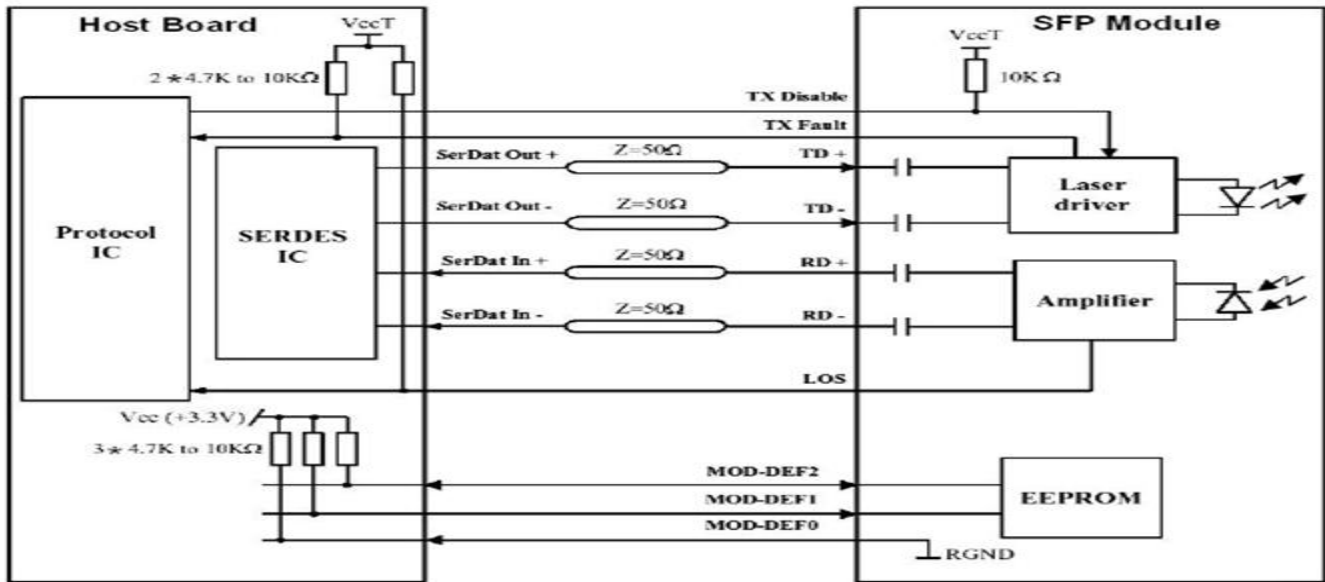

Recommended Host Board Supply Filtering Circuit

The MSA power supply noise rejection filter is required on the host PCB to meet data sheet performance. The MSA filter incorporates an inductor which should be rated 400mA DC and 1Ω serial resistance or better. It should not be replaced with a ferrite. The required filter is illustrated in Figure. The MSA also specifies that 4.7K to 10KΩ pull-up resistors for Tx Fault, LOS, and MOD_DEF(0,1,2) are required on the host PCB. Figure is the suggested transceiver/host interface.

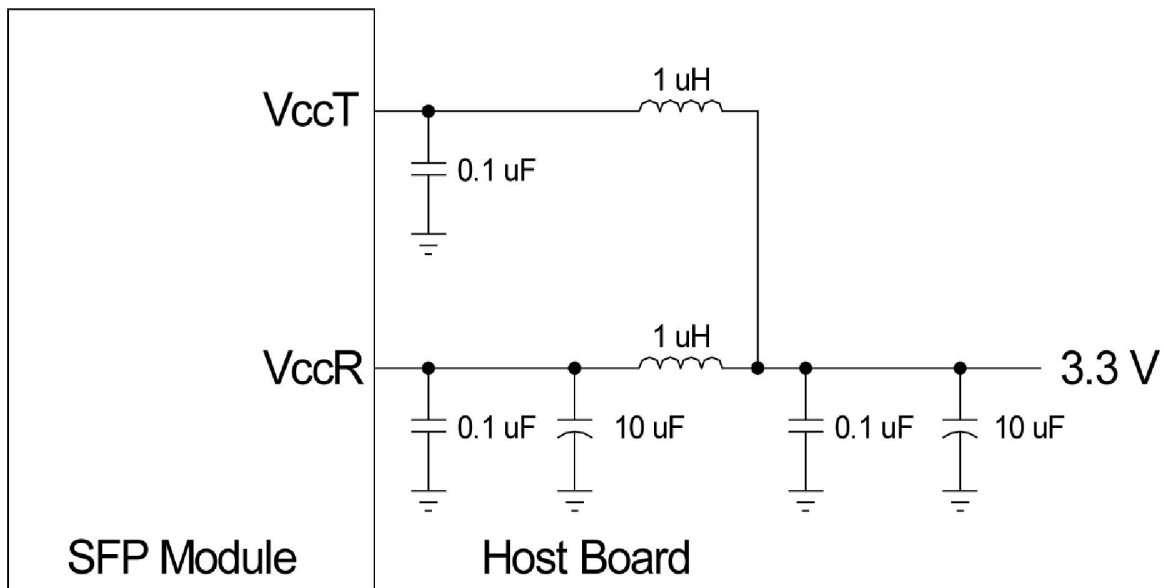

1.25G T1310/R1550nm 40km BIDI SFP Optical Transceiver Module

S-SB1G35L40-xD

Mechanical Dimensions

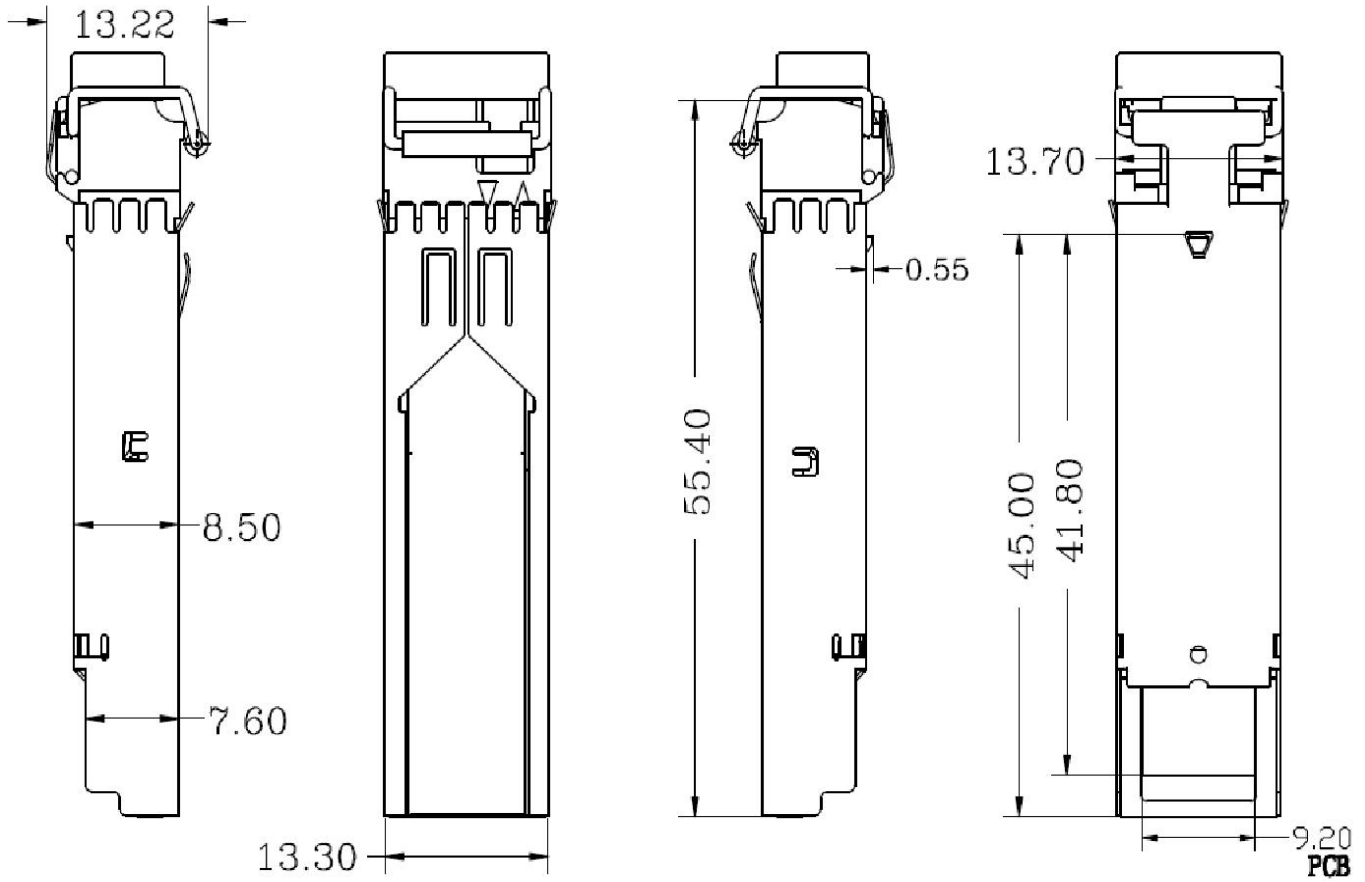

Ordering information

Part Number	Product Description
S-SB1G35L40-CD	BIDI SFP, 1.25Gbps, Tx1310/Rx1550nm, SM, 40km, 0°C~+70°C, With DDM
S-SB1G35L40-ID	BIDI SFP, 1.25Gbps, Tx1310/Rx1550nm, SM, 40km, -40°C~+85°C, With DDM